



Welcome To iTech University Seminars Presented by iTech Tool Technology Inc...

# Fastening Theory

**Pocket guide to tightening technique**

Learn the fundamentals of fastening theory and the importance of torque and clamp force in the bolted joint assembly:

- What is torque?
- Bolt Classification
- Yield
- Clamp Force
- Dynamic and Static Torque
- Joint Rate
- Prevailing Torque
- Overshoot
- Relaxation
- Elastic Interaction

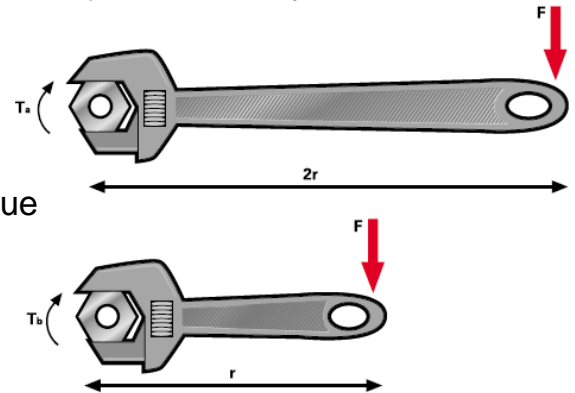

All participants will receive a pocket guide and certificate of achievement upon completion. **This seminar is approximately 1-2 hours long and is presented free of charge by iTech Tools.** Seminar can be held onsite or at our head office in Winnipeg.

